

2

1

B

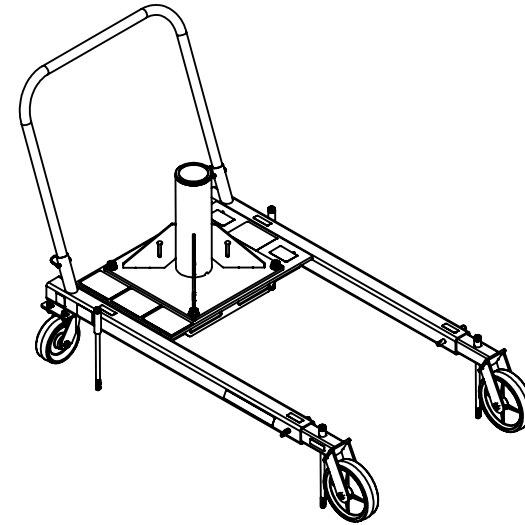
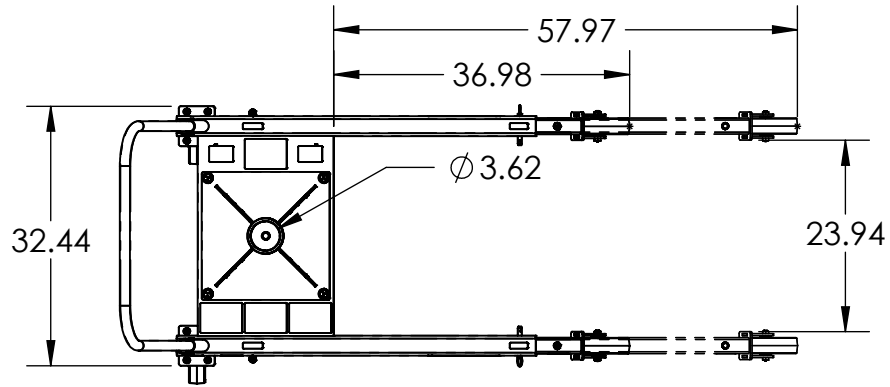

B

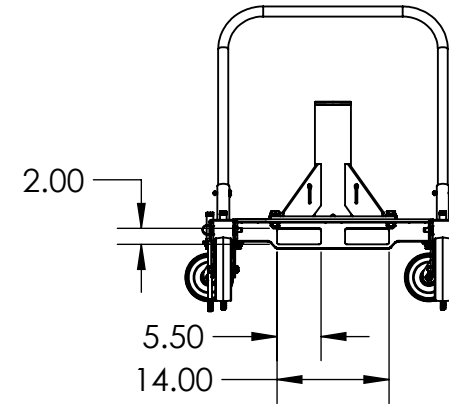
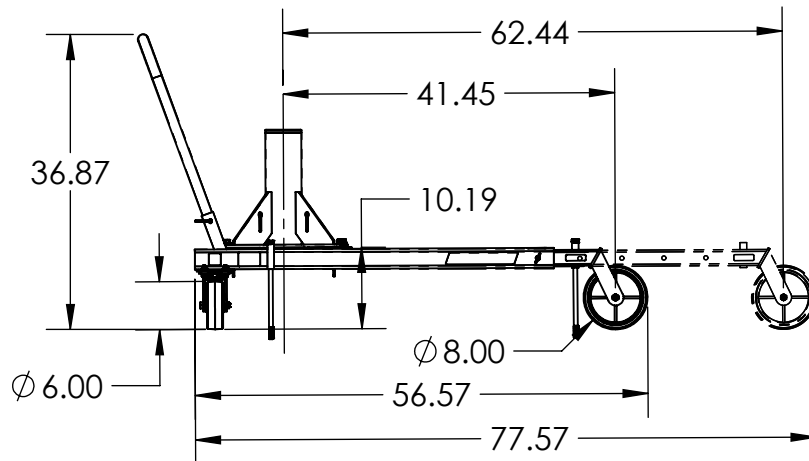

A

UNLESS OTHERWISE SPECIFIED:
 DIMENSIONS ARE IN INCHES
 TOLERANCES:
 FRACTIONAL $\pm 1/16$
 ANGULAR: MACH $\pm 1/2$ degree
 TWO PLACE DECIMAL $\pm .02$
 THREE PLACE DECIMAL $\pm .005$
 SPECIFIC TOLERANCES TO BE CALLED
 OUT IF NEEDED.

SURFACE AREA
 SQ. IN.

MATERIAL
 ASSEMBLY

FINISH
 OZ YELLOW POWDER

DO NOT SCALE DRAWING

PROPRIETARY AND CONFIDENTIAL

THE INFORMATION CONTAINED IN THIS
 DRAWING IS THE SOLE PROPERTY OF OZ LIFTING
 PRODUCTS. ANY REPRODUCTION IN PART OR
 AS A WHOLE WITHOUT THE WRITTEN PERMISSION
 OF OZ LIFTING PRODUCTS IS PROHIBITED.

	NAME	DATE
DRAWN	JMR	10/30/2023
CHECKED		

COMMENTS:



TITLE: WHEEL BASE 1

SIZE	Part #	REV
A	OZWB1	-

SCALE: 1:24 WEIGHT: 140.01 SHEET 6 OF 18

2

1

A