

ELECTRIC BUILDER'S HOIST



Features

- Lightweight and compact design for convenient mounting
- Automatic shut-off when rope reaches limit arm
- Dynamic and mechanical brake provides instant and safe braking
- Upper and lower limit switches for additional safety
- Sensor arm for motor shut-off to prevent reverse winding
- Galvanized wire rope with 360-degree weighted hook includes safety latch
- Quick release pendant and power cords
- Standard 115V power source-compatible
- Wireless remote control for ease of use (Model OBHW600 only)
- Emergency UP / DOWN control switch (Model OBHW600 only)
- Individual test certificate & serial number
- Wireless plug & play adapter available for OBH500 & OBH1000

75 fpm
OBH500

52 fpm
OBHW600

37 fpm
OBH1000



Standards - CE

	OBH500	OBHW600	OBH1000
Capacity - Full Drum (lbs)	500	600	1000
Motor Voltage	115/1/60	115/1/60	115/1/60
Speed (fpm)	75	52	37
Motor (HP)	1.74	2	2.41
Motor KW	1300W/17.5A	1500W/12.5A	1800W/15.5A
Lifting Height (ft)	90	90	90
Wire Rope (in)	3/16	3/16	1/4
Net Weight* (lbs)	54	49	73
Power cord length (ft)	15	15	15
Pendant length (ft)	65	n/a	65
Full Load (AMPS)	17.5	12.5	15.5
Duty Cycle (min)	15 (25%)	15 (25%)	15 (25%)

500, 600, 1000 LBS

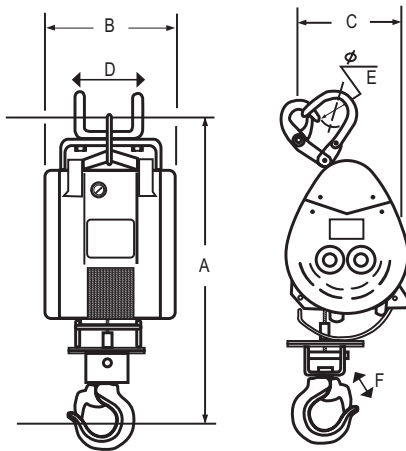

		OBH500	OBHW600	OBH1000
A (in)	Height	26.77	26.77	28.50
B (in)	Width	9.50	9.50	10.50
C (in)	Depth	7.88	9.06	12.00
D (in)	Hanger Width	4.50	4.50	5.50
E (in)	Hanger Opening	2	2	2
F (in)	Hook Opening	1.62	1.62	1.50

Dimensions and illustrations are for reference only and subject to change without notice.



WARNING
CANCER AND REPRODUCTIVE HARM
 Some products may contain chemicals known to the state of California to cause cancer, or birth defect or reproductive harm.
www.P65Warning.ca.gov

ELECTRIC BUILDER'S HOIST ACCESSORIES

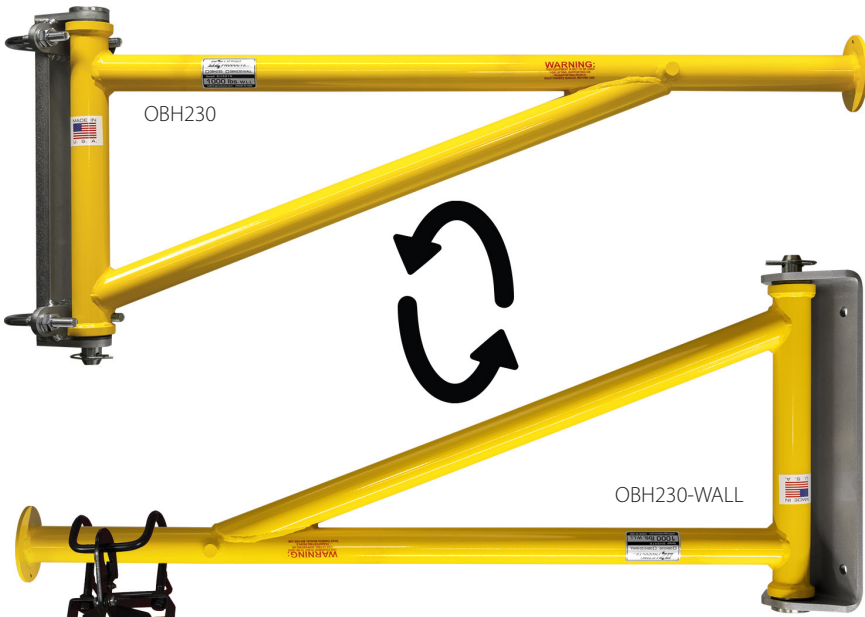

Mounting Arm Bracket (Pipe-Mount and Wall-Mount)

- Durable powder coat finish
- Solid mounting bracket
- Portable / Light Weight
- Quick mount
- Includes mounting template
- Made in USA

Both OBH230 and OBH230-WALL can be reverse mounted. Ideal for low headroom situations.

	OBH230	OBH230-WALL
W - Width (in)	40 1/2	40 1/2
H - Height (in)	17 3/4	17 3/4
D - Mounting Pipe (in)	2	N/A
Capacity (lbs)	1000	1000
Net Weight (lbs)	26	31



OBH500

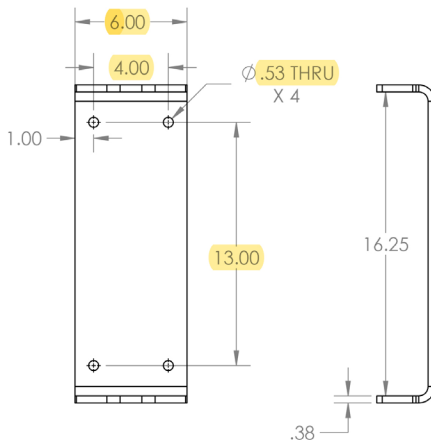

OBH230-WALL - Mounting bolt pattern

OBH-CLAMP Builder's Hoist Beam Clamp

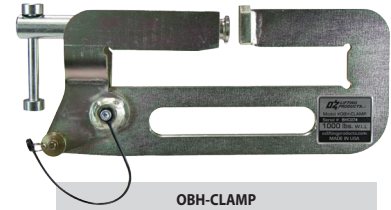

OBH-CLAMP	
A - Width (in)	13.5
B - Height (in)	5.375
Max flange width (in)	8
Capacity (lbs)	1000
Net Weight (lbs)	8



OZ05PBTA-OBH
Trolley with OBH Hanger
Refer to OZ05PBTA dimensions on page 15



OZ1GBT-OBH
Geared Trolley with OBH Hanger
Refer to OZ1GBT dimensions on page 19



OBH-HANGER
OBH Hanger



WARNING
CANCER AND REPRODUCTIVE HARM
Some products may contain chemicals known to the state of California to cause cancer, or birth defect or reproductive harm.
www.P65Warning.ca.gov