

INDUSTRIAL LEVER HOIST



Features

- All-steel construction
- Aluminum construction (¼ Ton Model)
- Long lasting powder coat finish
- Steel handle with rubber grip
- Minimal load lifting effort
- Weston-Style brake system with twin pawl design
- Zinc plated load chain
- Fully-enclosed gearing
- Load sheave bearings
- Forged alloy steel hooks
- Heavy-duty latches
- Carrying bag (¼ Ton Model)
- Individual test certificates & serial numbers

Standards - CE, ASME/ANSI B30.21, AS1418.2

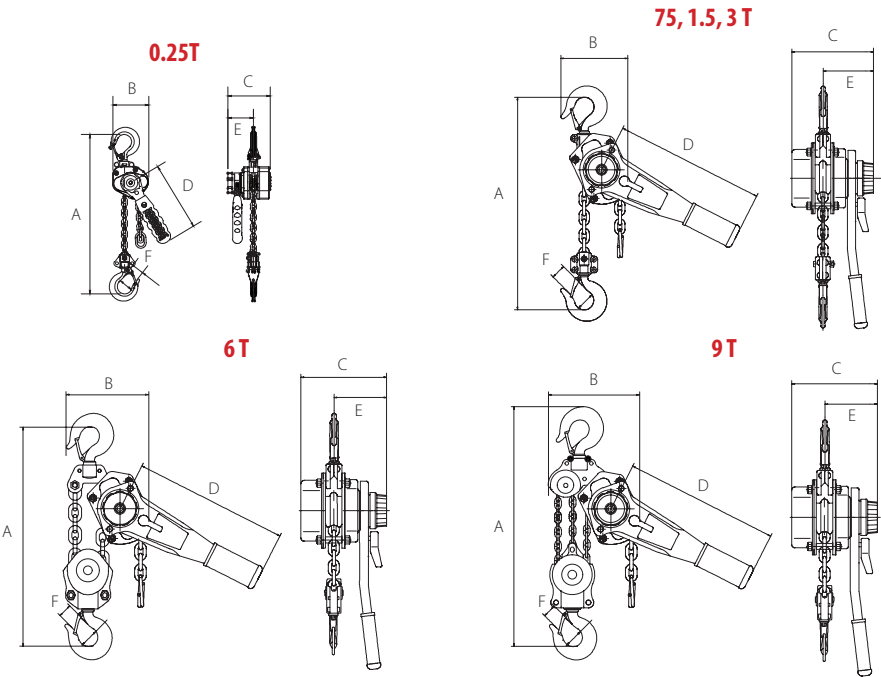

	OZIND025-XXLH	OZIND075-XXLH	OZIND150-XXLH	OZIND300-XXLH	OZIND600-XXLH	OZIND900-XXLH
Capacity (tons)	0.25	0.75	1.5	3	6	9
Effort to Lift S.W.L. (lb.)	44	31.4	49.5	72	76.5	81
Falls of Chain	1	1	1	1	2	3
Load Chain Diameter (mm)	4x12	6x18	8x24	10x30	10x30	10x30
Product Dimensions (in)	A	9.45	13.38	16.14	20.07	24.41
	B	3.62	5.31	5.91	8.27	9.53
	C	3.86	5.71	6.89	7.68	7.68
	D	6.3	12.2	16.14	16.14	16.14
	E	2.36	3.39	3.94	4.53	4.53
Hook-opening, Upper & Lower	F	0.83	1.18	1.26	1.50	1.89
Net Weight (lb.)	4	12	20	36	55	89

Standard Lift: 5, 10, 15 and 20 ft.

.25 T Models Standard Lift: 5 and 10 ft. We also do custom rigging

Dimensions and illustrations are for reference only and subject to change without notice. XX in hoist model number indicates length of lift by foot.



WARNING
CANCER AND REPRODUCTIVE HARM
 Some products may contain chemicals known to the state of California to cause cancer, or birth defect or reproductive harm.
www.P65Warning.ca.gov

OZIND075-10LH

**FREE
SPARE SET
OF LATCHES**

Excludes
¼ Ton Model

OZIND025-5LH

