

# PREMIUM LEVER HOIST WITH OVERLOAD PROTECTION



## Features

**Standard Overload Protection** – Overload Protection prevents the operator from exceeding the limitations of the hoist and is set at a minimum of 40% over the rated load.

**Free Wheel Feature** – When not under load, the operator can disengage the gearing by positioning the selection switch to the center position. This allows for a quick adjustment of chain for faster operation.

**Lifting or Pulling** – Can be used for lifting or pulling which makes it a more versatile tool.

**Minimal Load Lifting Effort** – Double reduction gearing provides easy operation with minimal lifting effort.

**360-Degree Handle Rotation** – Allows the operator to work in confined spaces.

**All-Steel Construction** – Featuring a long lasting powder coat finish, the all-steel construction ensures durable protection while providing a long and dependable service life in harsh environments.

**Weston-Style Brake System** – An enclosed and protected Weston-Style load brake stays clean and dry during the entire load operation. Also equipped with a unique twin pawl design for additional reliability.

**Enclosed Gearing** – Gears are protected from contamination and debris.

**Fully-Enclosed Lift Wheel** – Maintains smooth operation while distributing the load over more links of chain. It also helps keep debris from contaminating the lift wheel and self-cleans the chain as it enters the wheel.

**Sealed Roller Bearing** – This feature provides smooth, controlled operation of the gears and shafts. This ensures maintenance-free lubrication.

**Steel Handle with Rubber Grip** – Provides a non-slip, sure-grip surface.

**Forged Hooks** – Forged alloy steel hooks swivel 360° for easier attachment and positioning.

**Cast steel safety latches** – Heavy-duty, cast-steel safety latch has a bolt-and-lock nut connection. This feature simplifies changing latches in the field.

**Zinc-Plated Chain** – Provides a durable non-oily finish.

**Stainless Steel Riveted ID Tags** – Made from stainless steel the ID tag is corrosion resistant.

**Maintenance** – Hoists can be quickly disassembled for fast and easy maintenance. See the videos and maintenance breakdown animations at [OZLiftingProducts.com](http://OZLiftingProducts.com).

**Standard Lift Lengths** – 5,10,15, and 20 ft. Custom lengths available upon request.

**Safety Hooks & Shipyard Hooks** – Available for 1.5 and 3 Ton Lever Hoists.

**Individual test certificates & serial numbers.**

**Standards – CE, ASME/ANSI B30.21, AS1418.2**



**WARNING  
CANCER AND REPRODUCTIVE HARM**  
Some products may contain chemicals known to the state of California to cause cancer, or birth defect or reproductive harm.  
[www.P65Warning.ca.gov](http://www.P65Warning.ca.gov)



**OVERLOAD  
PROTECTED**

**FREE  
SPARE SET  
OF LATCHES**

OZ075-10LHOP

**.75, 1.5, 3T**

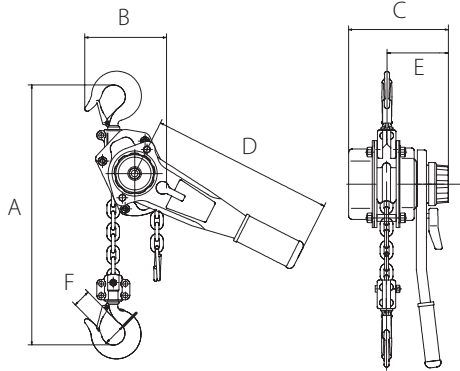

**6T**

**9T**

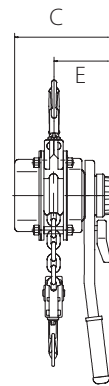
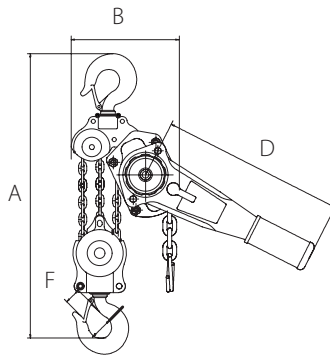
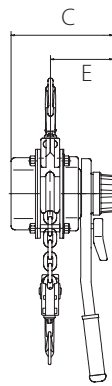
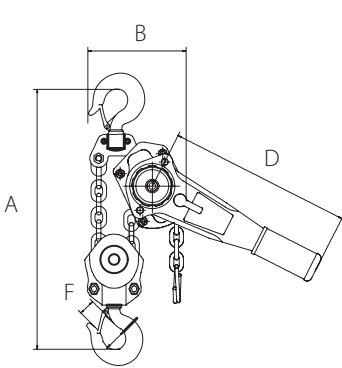

OZ600-15LHOP

	OZ075-XXLHOP	OZ150-XXLHOP	OZ300-XXLHOP	OZ600-XXLHOP	OZ900-XXLHOP	
Capacity (tons)	0.75	1.5	3	6	9	
Headroom (in)	12.79	14.96	18.90	24.41	27.56	
Effort on lever to lift full load (lb.)	30.86	48.50	70.55	74.96	79.37	
Falls of Chain	1	1	1	2	3	
Diameter of Load Chain (mm)	6x18	8x24	10x30	10x30	10x30	
Length of Lever Handle (in)	11.02	16.14	16.14	16.14	16.14	
Dimensional Information (in)	A	12.79	14.96	18.89	27.55	
	B	5.35	6.29	7.08	9.25	12.44
	C	5.82	6.77	7.87	7.87	7.87
	D	12.2	16.14	16.14	16.14	16.14
	E	3.54	3.85	4.52	4.52	4.52
Hook-opening, Upper & Lower (in)	F	1.18	1.26	1.50	1.89	2.13
Net Weight of Head Only (lb.)	13	22	33	51	81	

**Standard Lift Lengths: 5, 10, 15, and 20 ft. We also do custom rigging**

Dimensions & illustrations are for reference only and subject to change without notice. XX in hoist model number indicates length of lift by foot.

