

# SPARK RESISTANT CHAIN HOIST



## Features

Potentially explosive atmospheres exist in many areas of industry. Explosive zones carry extremely strict guidelines and equipment requirements. OZ Lifting Products' Spark Resistant Chain Hoists are manufactured in compliance with the EU's explosion-proof standard ATEX94/9/EC and the Machinery Directive 2006/42/EC. The explosion-proof level can reach: EX II2 GD c IIIC T135 °C. They are suitable for potentially explosive atmospheres including Zone 1 & 2 (gas) as well as Zone 21 & 22 (dust).

- Type EX-F3 Spark Resistant
- Unique Hand Wheel Design
- Minimal Load Lifting Effort
- Fully Enclosed Gearing
- Stainless Steel Safety Latches
- Stainless Steel Hand Chain
- Copper Plated Hooks Hand Wheel, and Roller Guides
- Individual Test Certificate and Serial Number
- Dacromet® Finish Load Chain
- Fully Machined Lift Wheel
- Totally Enclosed Gearing
- For Lifting or Pulling
- Low Headroom
- Weatherproof Load Holding Brake
- All Gears and Shafts on Roller Bearings
- Copper Riveted ID Tags

**FREE SPARE SET OF LATCHES**

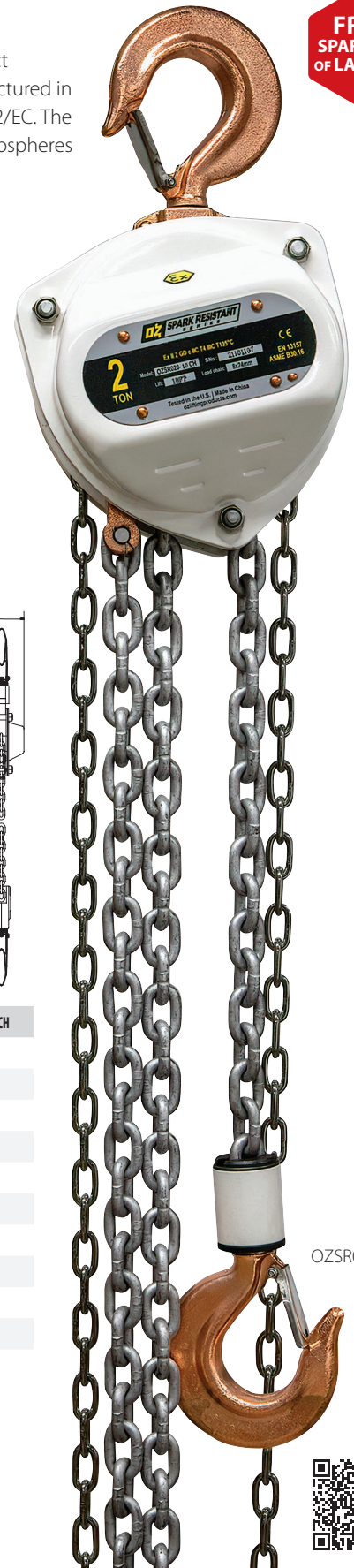

## Standards - CE, EX-F3 (Ex II 2 GD c IIIC T135°C), ASME/ANSI B30.16, AS1418.2

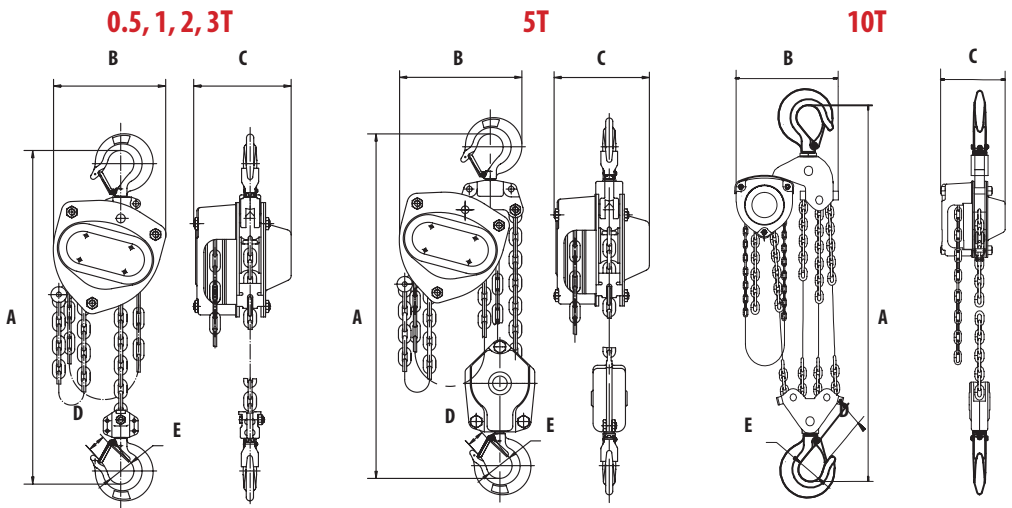

|                               | OZSR005-XXCH | OZSR010-XXCH | OZSR020-XXCH | OZSR030-XXCH | OZSR050-XXCH | OZSR100-XXCH |      |
|-------------------------------|--------------|--------------|--------------|--------------|--------------|--------------|------|
| Capacity (tons)               | 0.5          | 1            | 2            | 3            | 5            | 10           |      |
| Falls of Chain                | 1            | 1            | 1            | 1            | 2            | 4            |      |
| Effort to Lift S.W.L. (lb.)   | 54           | 56           | 75           | 83           | 85           | 87           |      |
| Loadchain Diameter (mm)       | 5x15         | 6x18         | 8x24         | 10x30        | 10x30        | 10x30        |      |
| Dimensional Information (in)  | A            | 13.58        | 14.80        | 18.50        | 22.83        | 30.71        |      |
|                               | B            | 5.82         | 6.77         | 8.26         | 10.03        | 15.16        |      |
|                               | C            | 5.19         | 5.94         | 6.88         | 8.07         | 7.44         | 7.44 |
| Hook-opening, upper & lower   | D            | 0.90         | 1.02         | 1.33         | 1.53         | 1.61         | 1.93 |
|                               | E            | 1.37         | 1.57         | 1.96         | 2.16         | 2.55         | 3.35 |
| Net Weight of Head Only (lb.) | 13           | 18           | 31           | 51           | 60           | 114          |      |

## Standard Lift: 10, 15, 20, 30 ft. We also do custom rigging

Dimensions and illustrations are for reference only and subject to change without notice. XX in hoist model number indicates length of lift by foot.



**WARNING**  
**CANCER AND REPRODUCTIVE HARM**  
 Some products may contain chemicals known to the state of California to cause cancer, or birth defect or reproductive harm.  
[www.P65Warning.ca.gov](http://www.P65Warning.ca.gov)

