

SPARK RESISTANT PUSH BEAM TROLLEY



Features

Potentially explosive atmospheres exist in many areas of industry. Explosive zones carry extremely strict guidelines and equipment requirements. OZ Lifting Products' Spark Resistant Push Beam Trolleys are manufactured in compliance with the EU's explosion-proof standard ATEX94/9/EC and the Machinery Directive 2006/42/EC. The explosion-proof level can reach: EX II 2 GD c IIC T135 °C. They are suitable for potentially explosive atmospheres including Zone 1 & 2 (gas) as well as Zone 21 & 22 (dust).

- Type EX-GCT Spark Resistant Equipped with anti-spark coating, suitable for potential explosive atmospheres.
- Copper plated wheels and lifting ring
- Copper riveted ID Tags
- Fits to most I, S, and W-Beams
- Precision ball bearing trolley wheels
- Anti-drop plate
- Individual test certificate & serial number



OZSR2PBT

Standards - CE, ATEX-GCT, (Ex II 2 GD c IIC T4 IIC T135°C), ASME/ANSI B30.11, ASME/ANSI B30.17, AS1418.2 (For use with manual or powered hoists)

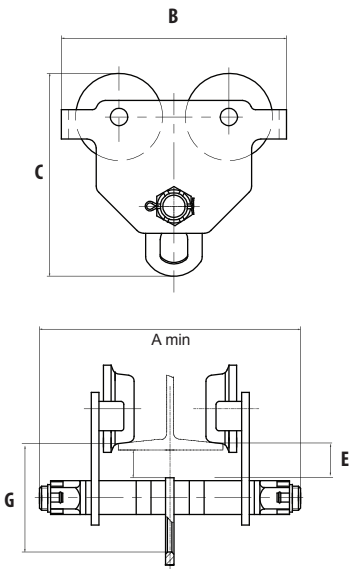

	OZSR05PBT	OZSR1PBT	OZSR2PBT	OZSR3PBT	OZSR5PBT	OZSR10PBT
Capacity (tons)	.5	1	2	3	5	10
Minimum radius curve (ft)	2.62	3.28	3.61	4.26	4.59	6.56
Product dimensions (in)	A min	11.61	12.24	16.89	17.52	19.29
	B	7.83	9.69	10.87	13.07	16.69
Product dimensions (in)	C	7.36	8.74	10.34	12.17	15.59
	G	4.13	4.92	5.91	6.73	7.48
Max flange thickness (in)	E	1.18	1.50	1.50	1.57	1.77
Adjustable flange width (in)	1.97-8.00	2.50-8.00	3.64-12.00	3.94-12.00	4.50-12.00	4.88-12.00
Net weight (lb.)	16	23	42	64	95	196

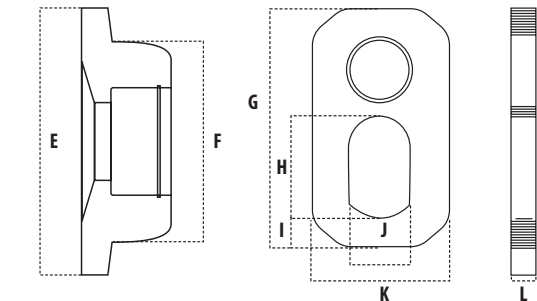

Wheel & Bail dimensions

SIZE	0.5T	1T	2T	3T	5T	10T
E	3.11	3.74	4.25	5.12	5.63	6.93
F	2.17	2.68	3.15	3.94	4.33	5.35
G	3.50	4.02	5.12	6.02	7.24	7.68
H	1.26	1.58	2.05	2.48	2.95	4.72
I	0.57	0.59	0.71	0.87	1.18	1.77
J	0.98	1.18	1.50	1.58	1.97	2.84
K	1.97	2.44	2.95	3.35	4.25	11.42
L	0.24	0.32	0.47	0.55	0.63	0.98

Dimensions and illustrations are for reference only and subject to change without notice.



WARNING
CANCER AND REPRODUCTIVE HARM
 Some products may contain chemicals known to the state of California to cause cancer, or birth defects or reproductive harm.
www.P65Warning.ca.gov

