

# DYNAMOMETER EQUIPPED LEVER HOIST



## Features

The Dyno-Hoist provides an accurate and reliable reading of the weight of the load being lifted and displays "OVER" when you have reached 126% rated capacity of the hoist. The integrated dynamometer can display the load weight in kg or lb. and runs on standard AA batteries with a run time of 150 hours. When not in use the battery energy saving system turns off the dynamometer. This scale is used for weighing loads not for trade.

- All-steel construction
- Zinc plated load chain
- Fully-enclosed gearing
- Top & bottom hooks swivel
- Heavy-duty latches
- Weston-Style brake system
- AC power cord/charger included
- Steel handle with rubber grip
- Forged alloy steel hooks
- Minimal load lifting effort
- Long lasting powder coat finish
- Load sheave bearings
- Individual test certificate & serial number

**Standards - CE, ASME.ANSI B30.21, AS1418.2**

**0.75, 1.5, 3T**

**6, 9T** (9T pictured, 3 falls of chain)

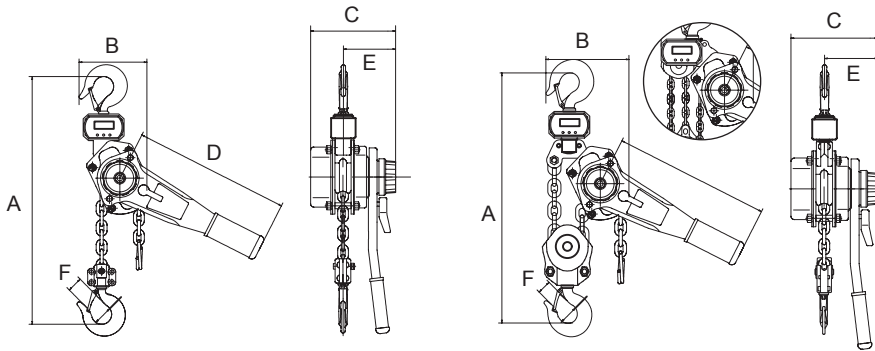

	OZDH075-XXLH	OZDH150-XXLH	OZDH300-XXLH	OZDH600-XXLH	OZDH900-XXLH
Capacity (tons)	0.75	1.5	3	6	9
Effort to Lift S.W.L. (lb.)	31.4	49.5	72	76.5	81
Falls of Chain	1	1	1	2	3
Load Chain Diameter (mm)	6x18	8x24	10x30	10x30	10x30
Product Dimensions (in)	A	15.96	17.73	21.82	26.41
	B	5.28	5.91	7.48	9.53
	C	5.71	6.89	7.68	7.68
	D	12.2	16.14	16.14	16.14
	E	3.39	3.94	4.53	4.53
Hook-opening, Upper & Lower	F	1.18	1.26	1.50	1.89
Net Weight (lb.)	15	23	40	58	90

**Standard Lift: 5, 10, 15, 20 ft. We also do custom rigging**

Dimensions and illustrations are for reference only and subject to change without notice. XX in hoist model number indicates length of lift by foot.



**WARNING**  
**CANCER AND REPRODUCTIVE HARM**  
 Some products may contain chemicals known to the state of California to cause cancer, or birth defect or reproductive harm.  
[www.P65Warning.ca.gov](http://www.P65Warning.ca.gov)

